

ICP-MS-3700



EPCC / PRODUCTS / APPLICATION / SOFTWARE / ACCESSORIES / CONSUMABLES / SERVICES

Analytical Technologies Limited

An ISO 9001 Certified Company

www.analyticalgroup.net

Third generation ICP-MS with continuous innovation and progress

High sensitivity and reliability ICP-MS 3700 inductively coupled plasma mass spectrometer. ICP-MS was created after core technical difficulties were overcome in mass spectrometer such as flow field control of high temperature gas, multistage gradient vacuum, high sensitivity ion interfaces, distributed collision reaction cells, quadrupole mass analyzer with temperature and humidity resistance, and etc., which is combined with liquid chromatography, online gas dilution system, automatic rapid injection, oxy-combustion, laser ablation, direct injection in atmosphere, organic injection, and other specialized technologies, and meets the need of various professional applications; at the same time, the combination of element, a professional mass spectrometer software system, with standard methodology library, automatic tuning, guided operation mode and visualized status monitoring at any time, greatly reduces the difficulty of the operation of the mass spectrometry software system, and meets the extensive needs of laboratory applications.

New starting point for inorganic mass spectrometry



ICP-MS 3700 typical features

Through continuous product innovation, the ICP-MS 3700 offers faster analysis speed, higher sensitivity, better interference elimination effect, as well as specialized design that makes the application easier!

Excellent sensitivity

On the basis of the aerodynamic simulation design at the junction of thermal plasma and vacuum, the ion interface is optimized, and the sensitivity of ICP-MS is increased by 3 to 5 times; and the detection limit as low as ppt is more suitable for the detection of high-purity materials and high-purity reagents.

Excellent matrix resistance

The matrix resistance of the ICP-MS 3700 is so excellent that high salt samples of up to 10% can be injected directly, which is ensured through the fluid simulation of ion interfaces, design of two off-axes in the front and at the back, patented collision reaction cells, powerful self excited all solid state ICP ion source, argon online dilution, and other key technologies.

Unique design for reliability which improves stability

ICP-MS 3700 is currently the only ICP-MS that can operate on board. The product has been specially designed for shock absorption and all solid state, has passed comprehensive tests for road load data regarding road conditions when on board of vehicles, as well as practical application tests of tens of thousands of kilometers, and has demonstrated excellent reliability.

Specialized ICP-MS to solve special problems in applications

Fully automatic heavy metal analysis system for laboratory filter membranes, soil, and etc.

Online monitoring system for heavy metals in surface water

Online monitoring system for heavy metals in atmospheric particles

Heavy metal speciation analysis system based on LC-ICPMS Solid direct injection ICP-MS solves difficulties in the analysis of solid refractory samples

Online monitoring system on hydrometallurgical processes

Online monitoring system for impurity metal elements in high purity reagents for semi-conductors

Online monitoring system for radionuclides at hazardous locations

New starting point of inorganic mass spectrometry

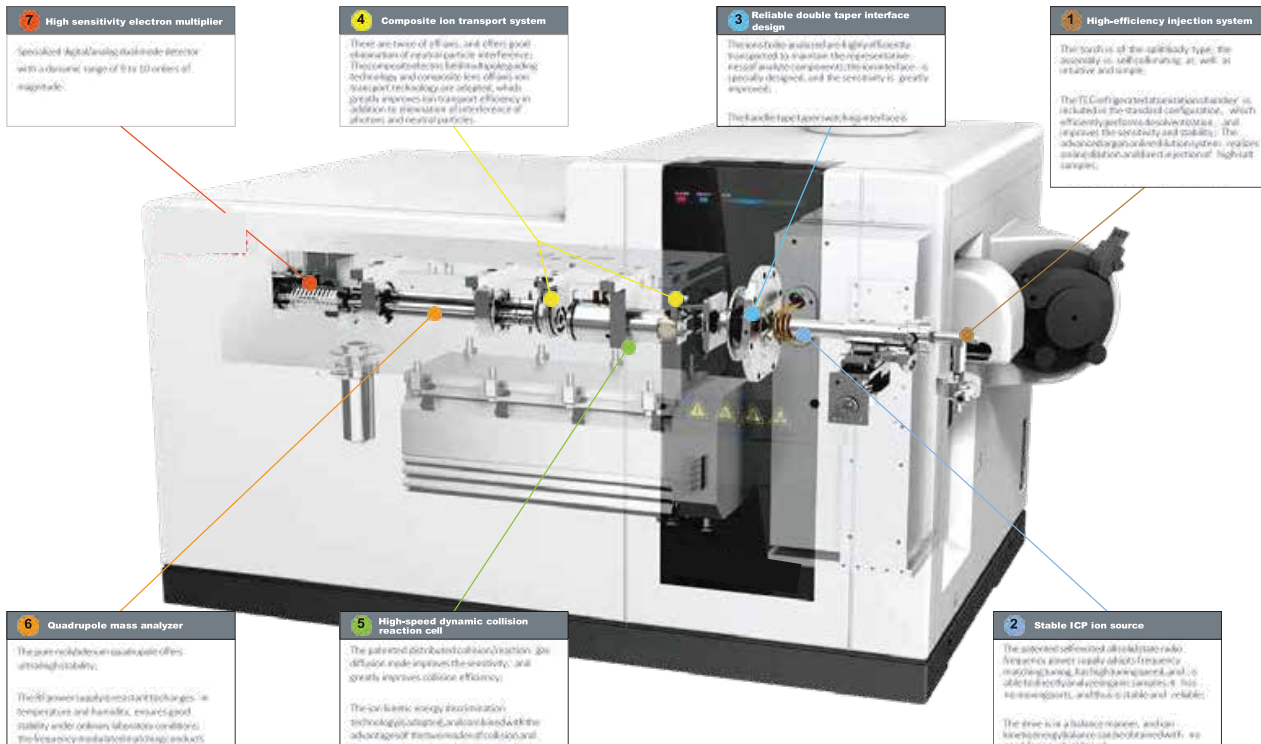

New starting point for inorganic mass spectrometry

1 High-efficiency injection system Split-body torch

Full split-body torch design, self-collimation installation, and simplified torch design greatly reduce the use cost of the torch. Only the central tube needs to be replaced for different injection requirements to meet their different injection requirements such as organic, high salt, high sensitivity, HF acid resistance, and etc.

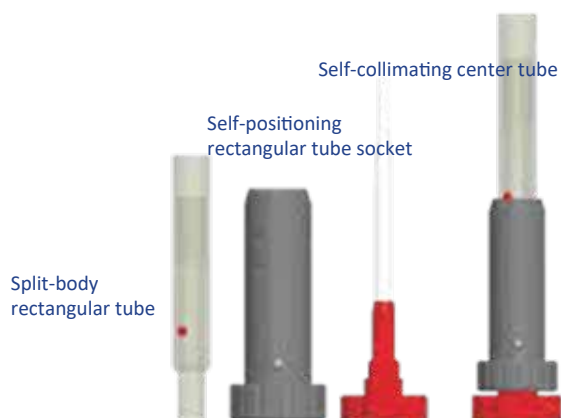

TEC refrigerated injection included in standard configuration

The injection system is equipped with a TEC refrigeration module in the standard configuration, which greatly improves the continuous working stability of the instrument and its ability to analyze organic solvents, and effectively reduces oxide productivity.



Full MFC gas control system

A highly integrated high-precision digital MFC gas circuit controller with a control accuracy of $<0.5\%$ is adopted. Up to seven channels of MFC can be deployed. Additional dilution gases, auxiliary oxygen, two-way collision gases, and etc. can be deployed in addition to the atomizing gases, auxiliary gases, and cooling gases



Online argon dilution system (AGOD)

The system is suitable for complex sample injection analysis under high salt matrix, and is capable of high salt resistant injection analysis and online dilution working mode. The AGOD uses a conventional sampling system, and combines with stable plasma conditions; its sampling depth is deeper and its carrier gas flow is lower. There is a second argon gas flow added between the atomization chamber and the rectangular tube to dilute the sample aerosol before it enters rectangular tube to reduce the total amount of sample that enters the plasma, so that direct analysis can be conducted without adding any reagent or diluting solution



Injection by 12-rotor high-precision peristaltic pump

The twelve-rotor high-precision peristaltic pump is equipped in the standard configuration, with optional pump tubes of various materials such as PVC, Solva, Tygon, Viton, and etc., to meet the various needs for the conventional, organic solutions, and long service lives; the optional flared pump tubes greatly reduce the difficulty to use.



The superior analytical capability comes from innovation in every detail

2 Stable ICP ion source

Patented self-excited all-solid-state ICP ion source

No matching box needed, millisecond-level fast frequency conversion to match with plasma load changes, and no easy flameout;

Improved matrix resistance, such as direct injection of buffer salt in arsenic speciation analysis;

Able to analyze volatile organic solvents, such as: 100% acetonitrile, 100% methanol;

Balanced drive to reduce ion kinetic energy dispersion and secondary ion generation, without the need for shielding;

Water cooling to ensure long-term stability



RF power supply

iStandby mode

The mode includes automatic low-power standby between analysis intervals, which greatly reduces consumption of argon gas and power, and automatically returns to normal working conditions along with sample injections

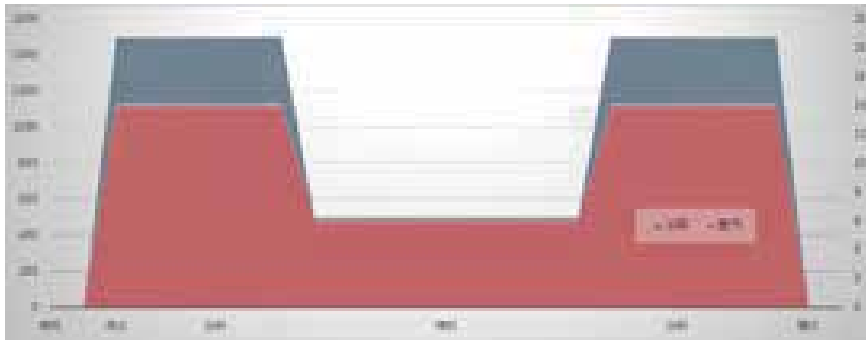

3 Reliable double taper ion interface

Optimized ion interface design

The improved double taper interface perfectly realizes the transition from atmospheric pressure to high vacuum, realizes the effective extraction of representative ions during the transition from ultra-high temperature to normal temperature, and effectively reduces the vacuum load.

Through aerodynamic simulation

The double cone design is optimized, and the performance of the instrument is greatly improved.

The salt deposition is reduced, and the matrix resistance is improved.

Extraction lens

Any voltage from -200 to +5V can be applied on the lens, and the extraction voltage can be adjusted arbitrarily for different ions and sample matrices;

The positive voltage can completely isolate the ions, prevent the ions from entering the ion optical system, and cause unnecessary pollution during standby

Minimalist handle type taper switching system

Innovative handle type taper switching system with interlock protection to prevent abnormal operations;

Maintenance through the switching of tapers is easy and convenient which needs no vacuum venting.



Handle type taper switching system

New starting point of inorganic mass spectrometry

High-efficiency ion optical system

The double taper interface realizes efficient transport of ions under analysis.

The two off-axes in the front and at the back can effectively eliminate the interfering particles (neutral particles, electrons, photons).

The patented collision reaction cell technology and distributed intake system minimize the interference.

The pure molybdenum quadrupole mass analyzer is the most stable choice for high resolution mass spectrometry.

The dynamic range of the dual mode discrete dynode is up to 9 ~ 10 orders of magnitude

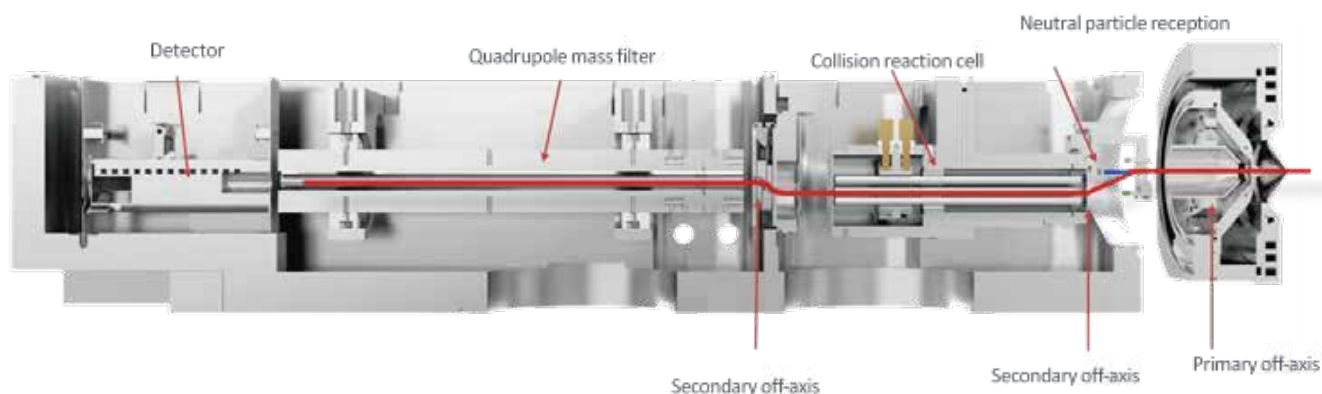

4 Composite ion transport system

Unique ion channel

- The channel can be flexibly deployed under high sensitivity mode or salt resistant mode with the help of such interface technologies. The taper material is either nickel or platinum.
- The high salt resistance mode ensures the stability of long-term analysis of high salt samples.
- The high sensitivity mode can meet the application requirements of high-throughput analysis of different types of samples Open ion deflection lens
- The big opening primary deflecting lens can improve the ion transmittance and hence the sensitivity.
- The special neutral particle reception system cleans the ion lens with no need for replacement.

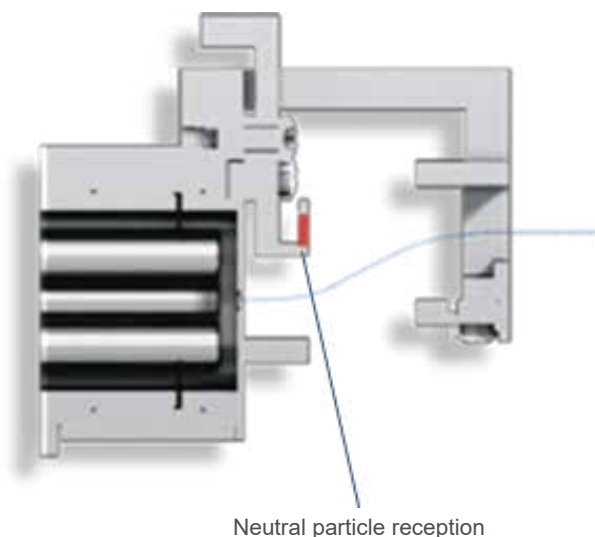

Neutral particle reception

5 High speed dynamic collision reaction cell

- The collision reaction cell with compound electric field has the advantages of small cell volume and high ion transfer efficiency
- The patented distributed collision / reaction gas diffusion results in a good gas distribution in the cell, and thus greatly improves the collision efficiency and sensitivity.
- The Kinetic Energy Discrimination (KED) provides excellent interference elimination capability.
- Direct dilution injection of blood / serum sample can be achieved, which provides good interference resistance.



Excellent performance created by excellent ion optics

6 High precision quadrupole mass analyzer

Unique pure molybdenum quadrupole



Temperature and humidity sudden changes resistant RF power supply for mass spectrometry

- The patented closed-loop adaptive adjustment technology for double channel RF power supplies to improve the stability of the power supply.
- The patented alternating temperature and humidity changes resistant technology provides adaptation to working environment of (15 ~ 35) °C and (20 ~ 80) % R. H.

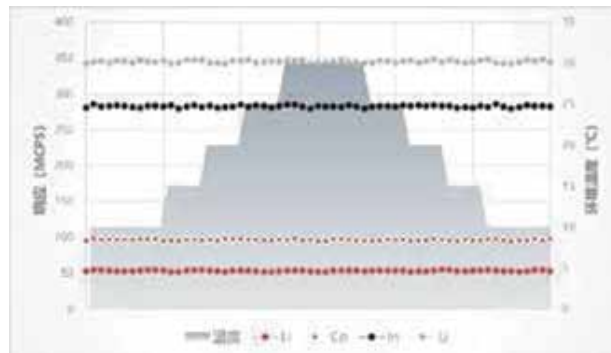
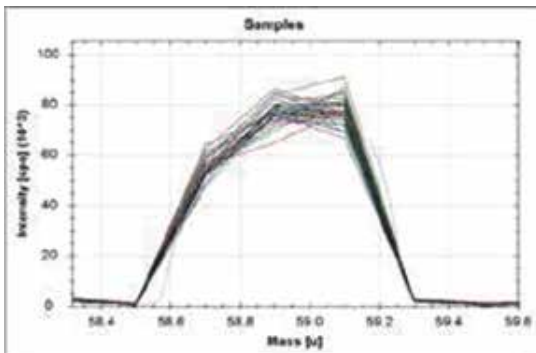

Outstanding interference elimination capability

Collision mode + KED to eliminate interference on mass spectrometry.

In the ICP, the polyatomic ions introduced by the solvent and sample matrix may result in serious interference in some target analytes. Therefore, the collision reaction cell (CRC) technology is used to eliminate this interference in quadrupole ICP-MS instruments. ICP-MS 3700 is equipped with a new hexapole collision reaction cell system, which greatly enhance the interference elimination efficiency through collision, while maintaining the high-efficiency ion transmission capability. Combined with the ked working mode, ICP-MS 3700 provides unparalleled performance in the simultaneous analysis of multiple elements in complex matrix samples.

The patented waterfall flow type distributed gas injection system can achieve gas replacement in the cell most efficiently and quickly. The system can, while improving the collision effect, greatly improve the gas replacement speed, and reduce the analysis waiting time.

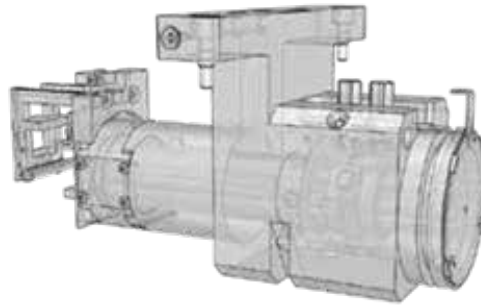

Kinetic energy discrimination (KED) working mode: The energy loss of each collision between the ion to be measured and the He atom is the same as that between the polyatomic ion and the He atom; yet since the polyatomic ion is larger than the ion under analysis, its chance of collision is therefore greater. At the outlet of the cell, the kinetic energy of the ion to be measured and the interfering ion is no longer the same due to the different times of collisions, and the polyatomic interfering ion will be blocked by potential well voltage blocking of at the quadrupole entrance due to the large kinetic energy loss, and won't be able to enter the mass analyzer.

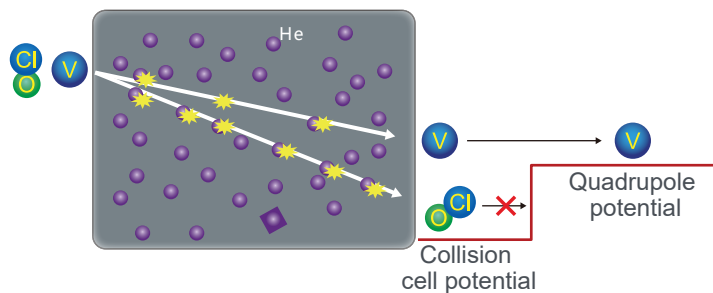

The detection of trace V in blood samples is easily interfered by ClO ions. It is difficult to detect the level of V of < 0.1 ppb in the conventional collision cell. The ICP-MS3700 patented hexa pole collision cell, in combination with KED, can be used to detect trace V in the blood perfectly.

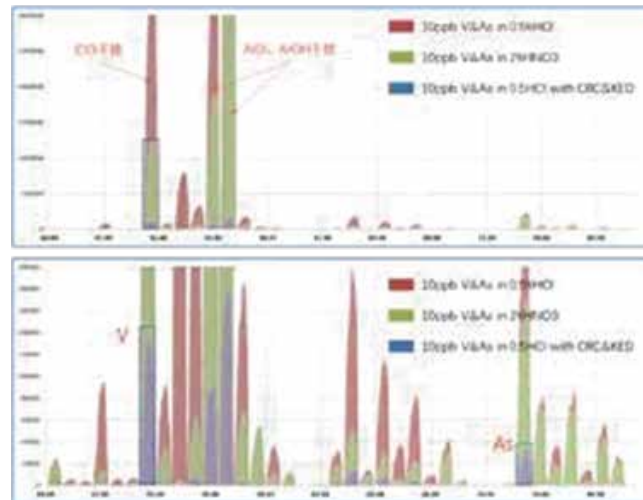

Morphology analysis & direct analysis of solids

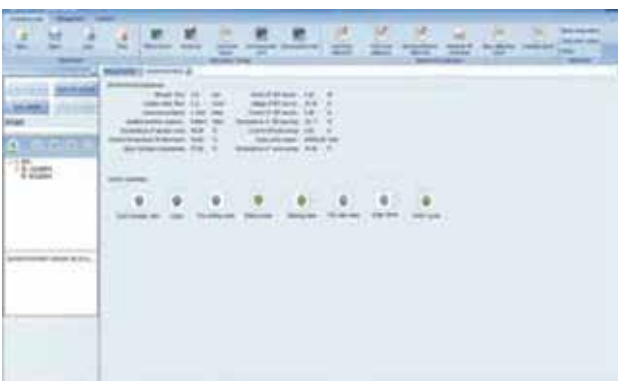

Visualized operation monitoring Real-time display of key operation parameters Inter-lock protection is adopted for plasma in operation (argon, cooling water, ventilation, torch chamber, waste liquid, and temperature)



ICP-MS 3700 Technical Specifications of Inductively Coupled Plasma Mass Spectrometer(ICP-MS)

1.General requirements

As a new generation of heavy metal analysis system, the inductively coupled plasma mass spectrometer can be combined with LC, automatic sampler, automatic graphite digestion system and other connected technologies.

The system is widely used in water quality, soil, atmospheric particulate matter, solid waste, food, animals and plants, food contact materials, cosmetics, semiconductors, high purity materials, minerals, petrochemical, industrial products, textile and other fields, and meets the requirements of relevant national standards for analysis methods.

2. Technical requirements:

2.1 Ion source:

Balanced drive, reduce ion kinetic energy dispersion, reduce secondary ion production, without additional expensive consumables such as shielding ring, can eliminate the secondary arc discharge of the cone mouth, prolong the service life of the cone.

Provide 500W ultra-low power standby, reduce the argon consumption by more than 50%, and the argon consumption is only 5 L/min.

Interface: nickel and platinum. Handle type cone changing system, with interlock protection, to prevent abnormal operation. Simple external cone maintenance, without vacuum leakage can be convenient cone maintenance, and avoid coil damage.(10 sets of cones shall be provided for cone replacement)

Extraction lens: The extraction lens can use zero voltage, negative voltage and positive voltage and other extraction modes, unique design, maintenance-free cleaning.

Ion transmission system: low background ion transmission design, ion before and after two off-axis, to achieve the effective elimination of interference particles (neutral particles, electrons, photons), without the need to replace the cleaning ion lens.

Collision reaction cell: With a new six-pole collision / reaction cell system, the distributed intake system eliminates maximum interference, greatly improves collision efficiency and improves sensitivity. Four level bar mass analyzer: high precision pure Mo material quadrupole, ensure the best mass axis stability, using 2.0 MHz low frequency drive quadrupole, to obtain a wider mass spectrum analysis range and better mass axis stability.

Detector: pulse / analog dual-mode discontinuous tap pole detector can complete scanning and selection analysis (qualitative and quantitative analysis) during the first injection process, and can realize automatic switching between analog and pulse modes.

Plasma visual system: it has the function of real-time plasma observation with electromagnetic shielding. It can monitor the plasma state in real time through the workstation software, and monitor the state of plasma, cone mouth and central tube in real time to facilitate sample analysis, maintenance and confirmation.

Silent cover: Silent cover can be configured to reduce laboratory noise and improve the laboratory analysis environment..

Sample injection system requirements:

Provide a variety of atomizers, including efficient quartz concentric atomizer with high salt resistance and PFA microinjection, with high atomization efficiency and hydrofluoric acid injection resistance.

Small volume inert cyclone atomization chamber, small dead volume, strong corrosion resistance, high aerosol atomization efficiency, low memory effect, standard TEC of refrigeration module, refrigeration temperature <-15%, improve the continuous working stability of the instrument and organic solvent analysis ability, reduce the oxide yield, improve the stability of the instrument.

Detachable quartz torch tube with split design, pre-collimated torch tube seat built-in air path connection, easy to operate card into the torch tube design, convenient for daily replacement and maintenance without removing the gas pipe.

A variety of central tubes are optional, and they are separated from the torch tube. For different applications, the central tubes can be replaced for organic, high salt, high sensitivity and HP acid resistance to facilitate replacement and maintenance.

High-precision gas mass flowmeter is equipped with standard control of four-way working gas, including atomized gas, auxiliary gas, cooling gas and collision gas. The fifth additional gas can be used as the dilution system.

Fully automatic on-line gas dilution device can be configured, which can dilute the sample matrix to less than 0.3% before the moment tube, ensure that the interface area and mass spectrum area are not contaminated by high matrix, eliminate the signal inhibition effect caused by high matrix, and have two working modes: preset dilution multiple and manual adjustment of the dilution gas flow. Conventional ICP-MS is resistant to ~0.2% salt tolerance and enables direct determination of > 10% salt content after dilution with argon.

Software requirements:

Operating system: well-known brand commercial computer, Microsoft® Windows 10, etc., multi-task, multi-user system software.

Automatic analysis functions (instrument visualization interface, automatic tuning, automatic diagnosis, customized user report, start and close vacuum, torch position adjustment, plasma parameters \ ion lens voltage optimization, standard \ collision pool, working mode switching, etc.).

Real time data display and real time report display.

Other intelligent functions include: dynamic adjustment of injection time and flushing time, user method library management, and QC function can meet the QC requirements of EPA method.

The ICP-MS operation software can also be installed on a personal computer, and the sample.

HPLC-ICP-MS interface: the existing HPLC and ICP-MS can control simultaneously with the same computer and the same set of software, to realize online automatic synchronous analysis system, including real-time display, real-time data analysis, spectrum superposition, retention time, peak integration, working curve, automatic injection analysis and other functions.

Automatic super microwave-ICP-MS interface can be configured with and can use the same computer and the same set of software to simultaneously control the automatic super microwave and ICP-MS, realize online automatic "one key" analysis, including acid, cover, digestion, volume, mixing, ignition, injection, sample, establish standard, report and a series of automatic functions.(Provide the screenshot of the proof of the official website)

Possess the ability to modify the software source code to meet special needs such as online monitoring.

Performance requirement

Mass range: 2-260 amu.

Mass resolution: high resolution and standard resolution, adjustment range 0.3-2.0amu. Continuously adjustable, both modes can be used during one method analysis in order to expand the sample analysis application by change resolution.

Linear dynamic range: greater than 9 orders of magnitude.

Background stability: defined as the mean of the background signal at 5amu, below 0.5 cps.

Short-term stability: 20 min stability RSD <2% Long-term stability: 2-hour stability RSD <3%

Sensitivity: under the same instrument conditions, the sensitivity of Li should be above 20 Mcps / ppm, In should be above 180 Mcps / ppm, and U should be above 200 Mcps / ppm.

Double charged ions and oxide ions: Ce⁺⁺ / Ce⁺ below 3%, CeO⁺/Ce⁺ Less than 3% of this amount of the.

Limit of detection: The detection limit of Li should be lower than 2ppt, In, which should be lower than 0.1ppt, The detection limit of U should be lower than 0.1ppt.

Abundance Sensitivity: Low mass end: 1×10^{-6} ; High-quality end: 5×10^{-7}

Stability of the mass axis: <0.05 amu / 24h.

Isotope ratio accuracy: < 0.2% (¹⁰⁷Ag/¹⁰⁹Ag), equipped with isotope ratio measurement capability.

3.Configuration requirements:

- Icoupling mass spectrometer host, including:
- Sample cone / intercept cone.
- The RF generator.
- Deflected ion lens.
- The collision reaction pool.
- Full mass flow gas controller.
- The detector.
- Mechanical pump.
- Four-channel peristaltic pump.
- Pressure-reducing valve.
- Rol chamber assembly.
- Quartz concentric atomizer assembly.
- Central pipe assembly of quartz moment tube.
- The ICP-MS dedicated analysis software and the online help system.

- Fast injection sample control software module.(Provide proof of software screenshots.)
- ETV solid injection control software module.(Provide proof of software screenshots.)
- Control software module of fully automatic super microwave digestion device.(Provide proof of software screenshots.)
- One set of tuning fluid and internal standard solution.
- **One-year consumables requirements: (not included in the random consumables)**

quartz moment tube 1piece

Peristtic pump drain tube 1 pack

Peristtic pump into sample tube 1 pack

Internal label into the sample tube 1 pack

4.Other supporting configuration requirements

- **Computer system**
I5-8500,8G, 1TB hard drive, 23-inch HD monitor, dual network card.
- **Cooling of the circulating water system**
Refrigeration capacity is 2100W, water tank volume is greater than 2L, and voltage is 220V.
- **The Laser Printer**
Black and white laser printer
- **AC parameter voltage regulator**
15 KVA, input voltage of 140V-300V, output voltage of 220 V \pm 1%.
- **Uninterruptible power supply**
10 KVA, one hour delay, high frequency UPS, configured with 12 V 38 AH-16.

HPLC Servicing, Validation, Trainings and Preventive Maintenance :

HPLC Servicing :HPLC Servicing : We have team of service engineers who can attend to any make of HPLC promptly @the most affordable cost.

Trainings :We also take up preventive Maintenance to reduce downtime of HPLC's Trainings.

AMC's/CMC :AMC's/CMC :We offer user training both in-House and at customer sites on HPLC principles, operations, trouble-shooting.

Validations :Validations :We have protocols for carrying out periodic Validations as per GLP/GMP/USFDA norms.

Instruments :Instruments :We offer instruments/Renting Services Modules like pumps,detector etc. on Rent.



About Analytical Technologies

Analytical Technologies is synonymous for offering technologies for doing analysis and is the Fastest Growing Global Brand having presence in at least 96 countries across the global. Analytical Technologies Limited is an ISO:9001 Certified Company engaged in Designing, Manufacturing, Marketing & providing Services for the Analytical, Chromatography, Spectroscopy, Bio Technology, Bio Medical, Clinical Diagnostics, Material Science & General Laboratory Instrumentation. Analytical Technologies, India has across the Country operations with at least 4 Regional Offices, 6 Branch Offices & Service Centers. Distributors & Channel partners worldwide.

Our Products & Technologies



UV/VIS
Spectro 2080+
Double Beam



Infra FTIR



Optima Gas
Chromatograph
3007

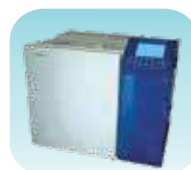

Optima Gas
Chromatograph
2979 Plus



Flash
Chromatograph



Atomic Absorption
Spectrophotometer



Liquid Partical
Counter



Optical Emission
Spectrophotometer



DSC/TGA



Semi Auto Bio
Chemistry Analyzer



HEMA 2062
Hematology
Analyzer



Micro Plate
Reader/Washer



URINOVA 2800
Urine Analyzer



Total Organic
Carbon 3800



Fully Automated
CLIA



NOVA-2100
Chemistry Analyzer



PCR/Gradient PCR/
RTPCR



TOC
Analyzer



Laser Particle
Size Analyzer



Ion Chromatograph



Water purification
system

Regulatory compliances



Corporate Social Responsibility

Analytical Foundation is a nonprofit organization (NGO) found for the purpose of:



Analytical Foundation

1. Research & Innovation Scientist's awards/QC Professional Award : Quality life is possible by innovation only and the innovation is possible by research only, hence ANALYTICAL FOUNDATION is committed to identify such personalities for their contributions across various field of Science and Technology and awarding them yearly. To participate for award, send us your details of research / testing / publication at Info@analyticalfoundation.org

2. Improving quality of life by offering YOGA Training courses, Work shops/Seminars etc.

3. ANALYTICAL FOUNDATION aims to DETOXYFY human minds,souls and body by means of yoga, Meditation, Ayurveda, Health Care, Awards, Media, Events, Camps etc.



HPLC Solutions MultipleLabs Analytical Bio-Med Analytical Distributors Analytical Foundation (Trust)

Corporate & Regd. Office:
Analytical House, # E67 & E68,
Ravi Park, Vasna Road, Baroda,
Gujarat 390 015. INDIA

T: +91 265 2253620
+91 265 2252839
+91 265 2252370
F: +91 265 2254395

E: info@hplctechnologies.com
info@multiplelabs.com
info@analyticalgroup.net

W. www.analyticalgroup.net
www.hplctechnologies.com
www.multiplelabs.com

Sales & Support Offices:
across the country :
Distributors & Channel
partners World Wide